

Diamondback XD Truck Scale

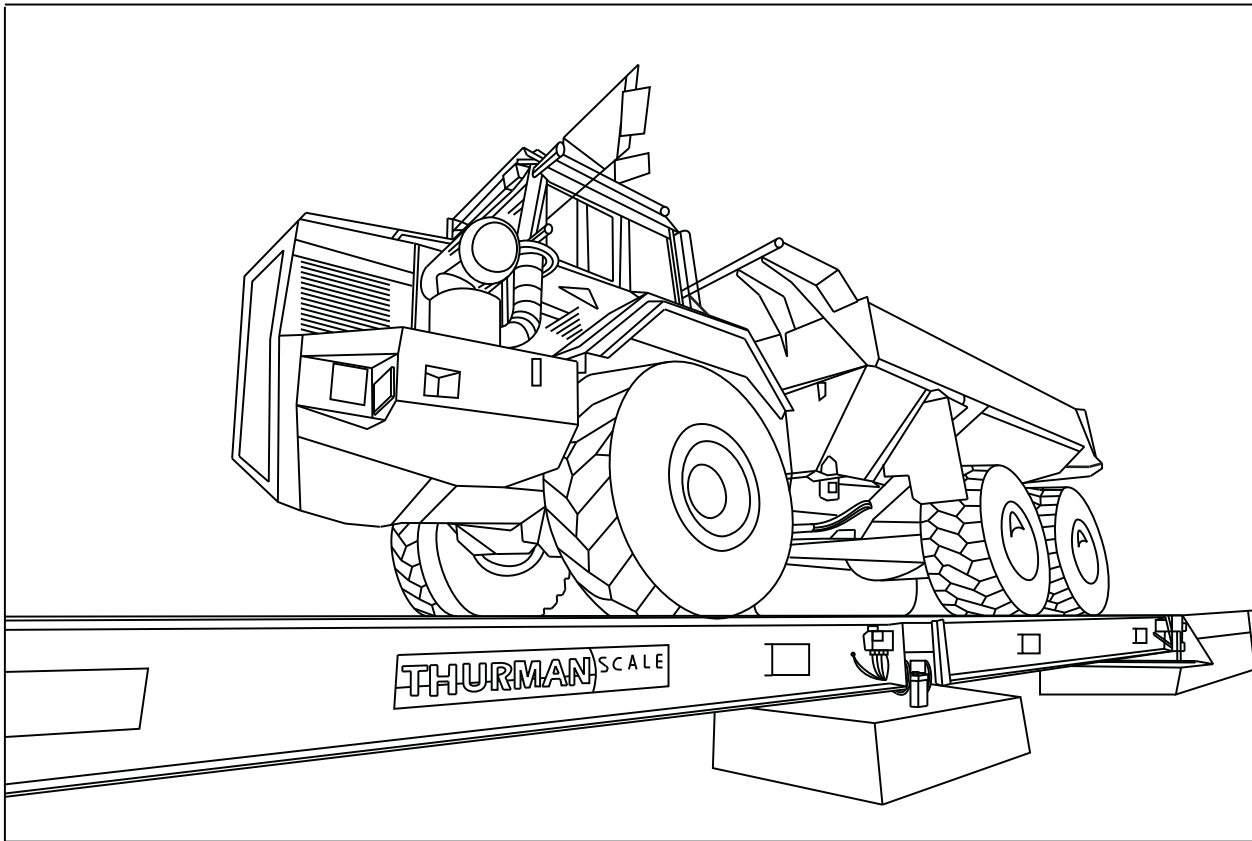



DISCLAIMER

Every effort has been made to provide complete and accurate information in this manual. However, although this manual may include a specifically identified warranty notice for the product, Thurman Scale makes no representations or warranties with respect to the contents of this manual, and reserves the right to make changes to this manual without notice when and as improvements are made.

Thurman Scale shall not be liable for any loss, damage, cost of repairs, incidental or consequential damages of any kind, whether or not based on express or implied warranty, contract, negligence, or strict liability arising in connection with the design, development, installation, or use of the scale.

© Copyright 2008

This document contains proprietary information protected by copyright. All rights are reserved; no part of this manual may be reproduced, copied, translated or transmitted in any form or by any means without prior written permission of the manufacturer.

Amendment Record

DIAMOND XD TRUCK SCALE

Installation Manual Document 51194

Manufactured by **Thurman Scale**
255 East Livingston Avenue
Columbus Ohio, 43215

Created	9/2008	
Revision 1	12/2008	Documentation Release

Table of Contents

SECTION 1: BASIC DESCRIPTION	7
Description	7
<i>Double Ended Shear Beam Load Cell Systems.....</i>	<i>7</i>
SECTION 2: INSTALLATION.....	9
Site preparation	9
Installing Stands, Suspension, and Modules.....	11
More about Installations	12
Typical Module Configuration	13
Set the Checking System.....	15
SECTION 3: WIRING FOR ANALOG SYSTEM INDICATORS.....	16
Wiring Steps.....	16
<i>Wire Load Cells into the Junction Boxes</i>	<i>16</i>
<i>Wire the Junction Boxes to Each Other.....</i>	<i>16</i>
<i>Weighbridge Module Interconnecting Cable Wiring Table</i>	<i>17</i>
<i>Wiring THE "J" BOX TO THE INDICATOR</i>	<i>17</i>
<i>Junction Box-to-Analog Indicator Wiring Table.....</i>	<i>18</i>
<i>Grounding for Analog Indicator.....</i>	<i>18</i>
<i>Data Recording.....</i>	<i>19</i>
<i>Moisture Protection.....</i>	<i>19</i>
SECTION 4: WIRING FOR INTALOGIX™ SYSTEMS	20
Introduction.....	20
Description	20
Installation.....	20
Load Cell Wiring	21
<i>Cell Numbering</i>	<i>21</i>
<i>Installation Information.....</i>	<i>22</i>
<i>Load Cell Connections at the SSC</i>	<i>22</i>
<i>SSC-to-SSC 'Daisy Chain' Connections.....</i>	<i>23</i>
<i>Dip (Address) Switch Setup, SSCs.....</i>	<i>23</i>
Power Supply	25
Grounding	26
Data Recording	26
SECTION 5: CALIBRATION	27
Initial Zero and Span Adjustments.....	27
Repeatability and Return-to-Zero Performance Tests	27
Section Test and Adjustment, Analog Systems	28
Section Test and Adjustment, Intalogix™ Technology Systems	29
Digital indicator initial and span calibration Analog Intalogix™ Technology.....	29

SECTION 6: PARTS	30
Scale Components	30
Analog Scale Components	30
Intalogix™ Technology Scale Components	30
APPENDIX I: WIRING	32
APPENDIX II: DATA RECORDING	33

Section 1: General Information

DESCRIPTION

The **Diamondback XD** is a uniquely designed truck scale.

- Built for extreme weighing applications.
- This scale combines an environmentally sealed, **Double-ended Shear Beam Load Cell System** with an above grade, low profile steel deck design.

The **Diamondback XD** consists of factory assembled steel deck modules.

- Each module connects to the adjoining module through the use of an exclusive connecting step hinge.
- The low profile foundation design offers many benefits over the traditional scale pit design including reduced construction costs and simplified maintenance.
- With the scale installed completely above ground, the load cell system, suspension components and weighbridge are not subjected to the harsh, corrosive environment found in a scale pit.



Double Ended Shear Beam Load Cell Systems

Double Ended Shear Beam Load Cell Systems use environmentally sealed cells and an exclusive parallel link suspension system.

- Parallel links offer load cell protection by absorbing the motion and shock caused by vehicles stopping and starting on the Weighbridge.
- The cells are nickel plated, internally potted with a patented material.
- They have welded covers over the internal strain gage for environmental protection and long life.



SPECIFICATIONS

<p>Platform Sizes</p> <ul style="list-style-type: none"> • Widths – 10’ to 14’ standard • Lengths – 60’ to 80’ standard • Custom lengths available <p>Scale Capacity – 135 tons</p> <p>Concentrated Load Capacity (CLC) – 130,000 lbs.</p> <p>Sections – 4 to 5</p> <p>Checking – CheckLink™ and Bumper</p> <p>Deck construction – Welded Steel Deck Plate</p> <p>Deck Height – 21.625</p> <p>Clearance – 5.375”</p> <p>Product Assembly – Modular</p> <p>Approvals – NTEP CC# 89-016</p>	<p>Load Cell</p> <ul style="list-style-type: none"> • Capacity – 100,000 lbs • Type – Double-ended Sheer Beam • Resistance – 3.0 mV/V • Cable Protection – Armour Guard™ • Approvals – NTEP CC# 06-114, Factory Mutual
--	---

Scale Options

Traffic Lights & Kits



Ticket Printers

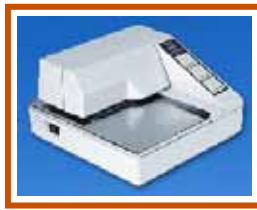

Instrumentation



Remote Displays



Rub Rails



Deck Runners



Section 2: Installation

SITE PREPARATION

Please refer to the ***data tag located on the Weighbridge*** to verify the capacity of the scale to be installed. Use certified prints for all concrete work.

1. Select a site which allows easy access to and from the scale, ensuring enough area for straight and level approaches to meet all state and local Weights and Measures regulations.
2. The site should have good drainage and surrounding areas must not drain into or through the scale site.
3. The soil must have a minimum bearing pressure of 3000 PSF, or as specified on the certified foundation drawings supplied by Thurman Scale.
4. Obtain all necessary permits and licenses prior to beginning construction.

NOTE: Always “*Call before you dig*”. **1-888-258-0808**

5. Using a transit, sight in and mark with stakes the area where the excavation is to occur and where concrete forms are to be built.
6. When constructing forms, make sure they are plumb, square, and level.
7. Place and compact gravel into the base of the forms if necessary.
8. Cut and position rebar into the form as per the schedule detailed on the certified foundation prints supplied by Thurman Scale.
9. The scale is designed to be anchored to the foundation through the use of the following:
 - Expansion anchors (included) which are inserted into the concrete after it has cured.
 - *Expansion anchors are recommended because of the flexibility allowed in final positioning of the scale.*
 - If poured in place anchors are being used, insert the anchor bolts into their proper positions within the forms, measuring out from the center line of the scale foundation.

SITE PREPARATION, CONTINUED

10. Pour concrete, using a mix to yield **a minimum 4000 PSI**. Vibrate the concrete into position to ensure consistency.
 - *All concrete work should conform to standards set forth by the American Concrete Institute Code.*
11. Remove forms and backfill for proper drainage.
 - A slope away from the scale is recommended.
12. Allow concrete to cure for 28 days or until a test cylinder indicates the concrete has reached its design strength before allowing traffic on the scale.

CAUTION

Module Assemblies are heavy and awkward to handle.

Exercise extreme care when lifting a module assembly so as to avoid personal bodily harm or damage to any equipment.

When lifting the modules, ensure that the lifting chains are equally loaded, secure, and that an **angle of greater than 30 degrees** is maintained.

INSTALLING STANDS, SUSPENSION, AND MODULES

Installing Stands, Suspension, and Modules for double ended Shear Beam DB Load Cells:

1. Using a chalk line, mark the foundation to determine the center line of the foundation and position of the anchor bolts using a Certified Print.
2. Place the load cell stands in position. Install the dowel pins into the top of the load cell stands. Install the clamp bars, retaining washers and nuts on the anchor bolts. Do not tighten it down at this time.
3. The load cells, links and load pins for the suspension system are shipped packed in the parts box. Remove these items and place one load cell, two (2) links and one (1) load pin by each load cell corner stand.
4. Position the load pins through the openings in each load cell corner stand.
5. Place a load link over each end of the load pin, resting the bottom of the link in the concave section of the pin.

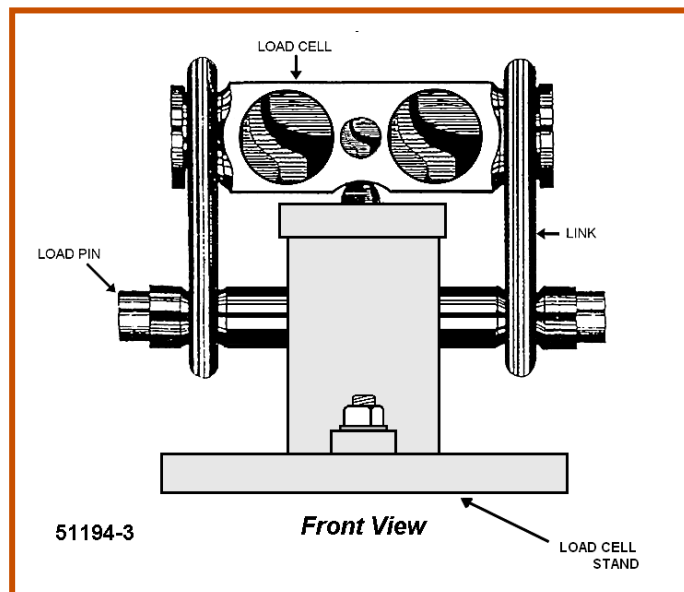

MORE ABOUT INSTALLATIONS

- The suspension components are installed on the load cells as each module is positioned.
- The weighbridge is shipped in one or more connecting modules, depending on the total length of the scale.

There are three different module configurations.

- The **Base** module has provisions for four load cells.
 - The **Intermediate** The intermediate module has connecting hinge plates on both ends of the module, and has provisions for two load cells.
 - The **End Module** contains connecting hinge plates on only one end, and provisions for two load cells on the opposite end.
- Modules are placed into position starting with the base module, then intermediate modules (if needed), with the end modules positioned last.

TYPICAL MODULE CONFIGURATION

Refer to *Thurman Certified Drawings* for your specific installation.

Length	No. of Modules	Type of Modules
60' to 70'	3	(1) Base, (1) Intermediate, (1) End
80'	4	(1) Base, (2) Intermediate, (1) End

- Using a crane of sufficient size, position the base module over the four load cell stands, with the Junction Box Mounts on the appropriate side.
- Carefully lower the module until it is approximately **six inches (6")** above the load cell corner stand.
- Position the load cells on top of the load cell corner stands, centering the load cells over the dowel pin of the stand (*with the cable toward the inside*).
- Place a load link over each end of the load cell. The load links should hang freely from the load cells with the load pin resting in the links.
- Position the load pins so that the pin seat load bearings of the weighbridge will rest on the ends of the pins when the module is lowered in place.
- Carefully lower the base module into position onto the load cell suspension assemblies.
 - Make sure that the pin seats are resting on the ends of the pins and that the links are hanging plumb.
- Remove the lifting chains and attach to the intermediate module, if used, depending on scale length.
- Lower the next module into place, aligning the module with the connecting step hinges of the preceding module, with the Junction Box Mounts on the appropriate side.
- Assemble the load cell suspension assemblies as described in **Steps 3 thru 6**.

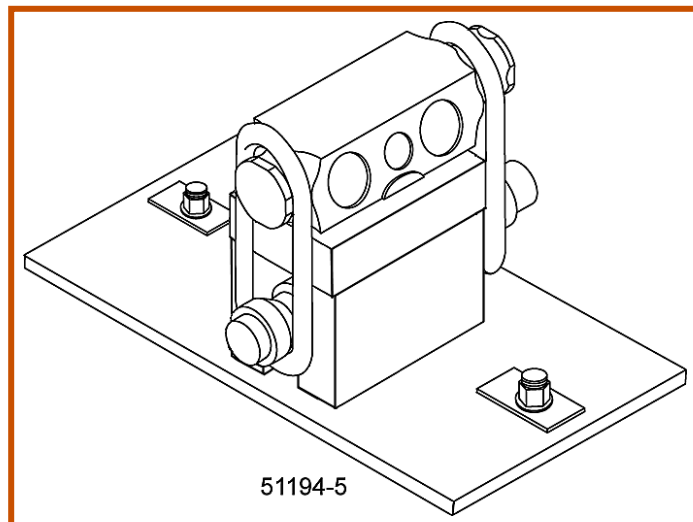

TYPICAL MODULE CONFIGURATION, CONTINUED

10. While the crane is still attached to the module, connect adjacent modules.
 - Use a 1" x 5" bolt with a 1" flat washer, a 1" lock washer, and a 1" hex nut..
 - The use of an Anti-Seize Lubricant is recommended.
11. Thread the bolt, but **DO NOT TIGHTEN DOWN** at this time.
12. Continue lowering the module so that it rests on the load cell assemblies.
13. Disconnect the lifting chains and attach to the next module to be set in place.
14. Repeat steps 7-13 until the last module has been replaced.
15. Check the gap between the end of the module and the approach wall.

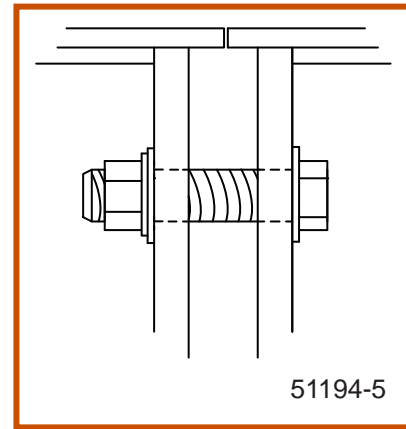

- This dimension should be equal to half of the difference between the overall foundation dimension and the scale length.
- Using a 70 ft. scale as an example, the overall foundation length is measured at **70'- 1½"**.
- The scale length is **70'- 0"**.
- The difference between the two dimensions equals **1½"**, and therefore the gap between the end of the scale and the approach wall should equal **¾"**.
- The gap between sections should be **1/8"**.
- If the measured dimension does not equal the calculated dimension, move the load cell corner stands until the gap measurement is absolutely correct.
- If necessary, add module shims between the modules on top of the lower step block.



16. Tighten all hinge bolts to a maximum of **180 ft/lbs.**

17. Tighten all the nuts on the anchor bolts.

SET THE CHECKING SYSTEM

1. Locate the four check bolts, two on each end of the scale (1 1/8" x 8").
2. Back off the jam nut and apply a quality anti-seize product to the threads on the bolt.
3. Thread each bolt in until it is approximately **1/8"** from the end wall bumper plate.
4. While holding the bolt in position, tighten the jam nut back down snugly.

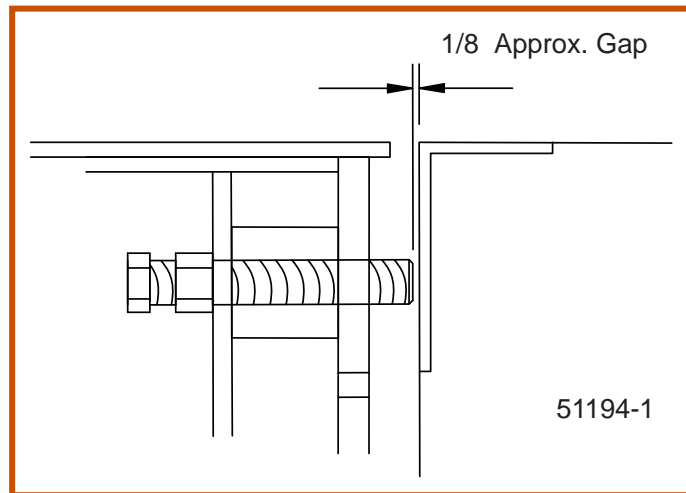

Section 3: Wiring for Analog System Indicators

WIRING STEPS

Wire Load Cells into the Junction Boxes

✓ **Important steps!**

1. Mount the Junction Boxes to the outside of the panels.
2. Remove the Junction Box Cover and Gasket.
 - *Keep out all dirt, dust, moisture or other debris from the Junction Box as damage to the Summing Board may occur.*
3. Route the Load Cell Cables into the Junction Box cavity.
 - a. Identify Load Cell Numbers
 - b. Wire to the proper terminals using the following chart:

Load Cell Wire Color	Function
Red	(-) Signal
White	(+) Signal
Black	(-) Excitation
Green	(+) Excitation
Bare/Orange/Yellow	Shield

Load Cell-to-Junction Box Wiring Table

Wire the Junction Boxes to Each Other

✓ **Important steps!**

4. Route the Module Interconnect Cable into the Junction Box mounting areas of the other section(s).
5. Pass the cable through the Sealing Hub, located at the end of the Junction Box, directly over the Terminal Strip marked "**Remote J-Box**".
6. Connect the cable to the terminals of the strip marked "**Remote J-Box**".
 - The wires **must be** connected so that the terminals match between the summing boards of the different sections.

WIRING STEPS, CONTINUED

Weighbridge Module Interconnecting Cable Wiring Table

Wire Color (Cable #66516)	Function
Red	(-) Signal
White	(+) Signal
Brown	(-) Sense
Black	(-) Excitation
Blue	(+) Sense
Green	(+) Excitation

7. Tighten the cable glands until the O-ring Clamps further around the wire.
 - If not tightened properly, moisture damage may occur.
8. Route the Indicator Interconnect Cable through the Sealing Hub on the Junction Box, located on the Base Module.

Wire the Junction Boxes to the Indicator

✓ Important steps!

9. Attach the indicator cable to the terminal strip marked **"Indicator"**
 - Match functions of the Digital Indicator to those marked on the Summing Board.
 - Using instruments with sense lines is strongly recommended for vehicle scale applications.

WIRING STEPS, CONTINUED

Junction Box-to-Analog Indicator Wiring Table

(Thurman Model IS-3000 A1, as an example).

Scale Model IS-3000 A1	Junction Box Terminal Strip marked 'Indicator'
1	(-) Excitation
2	(+) Excitation
3	(+) Sense
4	(-) Sense
6	Shield
7	(+) Signal
8	(-) Signal

NOTE: *Thurman Scale Model IS-3000 A1 Indicator designations are shown as **Terminal Locations** on the Load Cell Connector, TB-1, located on the PCB.*

Grounding for Analog Indicator

Proper grounding is important in any electronic system.

- See **Appendix I** for more information regarding this.
- Using a quality ohm meter, verify that a good connection exists between all of the following points:
 - Each Load Cell Case to the Weighbridge.
 - Each Load Cell Shield to the Junction Box Board Shield.
 - Junction Box Board Shield to the Weighbridge.
 - Module Interconnecting Cable Shield to each Junction Box Board Shield.
 - Indicator Connecting Cable Shield to the Junction Box Board Shield.
 - Indicator Connecting Cable Shield to the Indicator Case ground.
 - Weighbridge to a single properly placed Ground Rod.

WIRING STEPS, CONTINUED

Data Recording

- Record scale serial number from the tag.
- Record instrument, junction box and load cell serial numbers.
- Keep a copy of the sheet in the customer file.
- See **Appendix II** for more information regarding this.

Moisture Protection

Full Electronic Scales have been designed to provide protection from the effects of moisture.

- The load cells are calibrated with the cable attached.
- **The cable *MUST NOT* be cut.**
- The cable is connected directly to the Junction Box through a sealed bushing which ***MUST BE TIGHTENED WITH PLIERS*** to keep moisture out of the box.
- All cabling should have a **Drip Loop** at the cell or box entry location to help prevent water entry.
- On **all** boxes, the black plastic fittings have O-rings that can be forced out of position if the bushing itself is not tight.
 - To prevent this, first tighten the inner nut securing the bushing in the hole.
 - Then insert the cable and carefully tighten gland with pliers until it is very snug.
 - ***DO NOT over-tighten*** where bushing 'turns'.
 - All box covers ***MUST BE SECURED*** and tightened properly for protection against moisture.



Section 4: Wiring for Intalogix™ Systems

INTRODUCTION

Intalogix™ Systems use **Smart Sectional Controllers (SSCs)** and **Pit Power Supplies (PPSs)** for load cell excitation and signal processing.

DESCRIPTION

- One (1) SSC per section.
- One (1) PPS per platform unless the number and resistance of the cells require a second Pit Power Supply.
- SSC boxes have four (4) terminals, two (2) for load cells and two (2) for interconnections to other SSC boxes or terminating to a pit power supply
- All cell/section/scale adjustments are made via the Intalogix™ Technology instrument.

INSTALLATION

- **Boxes**

The box has tabs for bolting to mounting bars located on one side of each module.

- On SSC and PPS boxes, attach the Ground Wire Lug-to-one of the Mounting Bolt Studs.
- On PPS boxes, secure the isolated Ground Wire to the separate Ground Rod, as noted on the *Certified Print*.
- Tighten all connections securely to provide a good electrical ground.

- **SSCs**

1. Wire the load cells to the SSCs.
2. Connect the SSC to SSC cabling.
3. Set the address switches in the SSCs.

LOAD CELL WIRING

Intalogix™ installations use a different numbering system for load cells because of the digital addressing of the SSCs.

Cell Numbering

- With respect to the following starting position, face the platform from where the indicator is located.
- The cell at the upper left (far side) of the platform is **Cell One (1)**.
- The cell positions along the **far side** are **odd cell numbers**,
- The **near side locations** are **even cell numbers**.

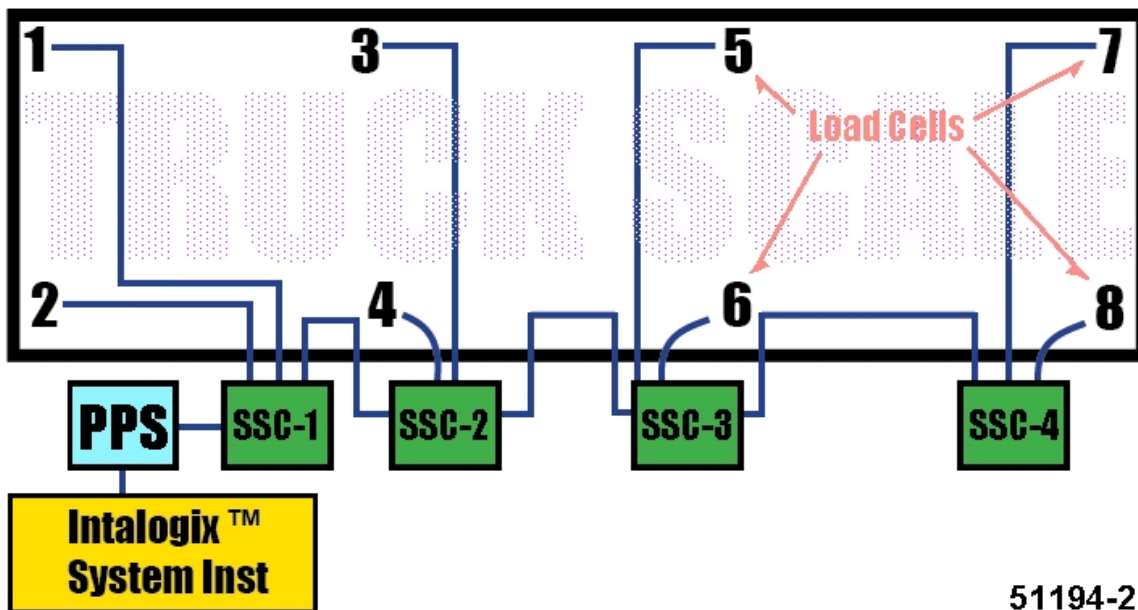

Above is an example of four (4) section cell numberings using SSCs.

NOTE: SSCs have connections for two (2) Load Cells, labeled **TB1** and **TB2**.

- The odd numbered cell goes to **TB1**.
- The even numbered cell goes to **TB2**.

LOAD CELL WIRING, CONTINUED

Installation Information

- The cable used in *all* wiring (other than load cells) must be a **minimum of 18 AWG (Cable 15602)**.
- The SSC boxes are daisy-chained to the end where they terminate into the Pit Power Supply (**24723**).
- Wire the Load Cells into each sections' SSC, as illustrated in **Appendix 1: Wiring, Drawing 51194-1d**.
- Load Cell Drain Wires, if applicable, connect to Ground Lug on the box exterior.

Load Cell Connections at the SSC

1. Wire the load cells into the SSC boxes.

TB1 or TB2 in SSC	Terminal Description	DE Shear Beam L/C Wire Color
1	(-) Excitation	Black
2	(+) Excitation	Green
6	Shield	Yellow (bare)
7	(+) Signal	White
8	(-) Signal	Red

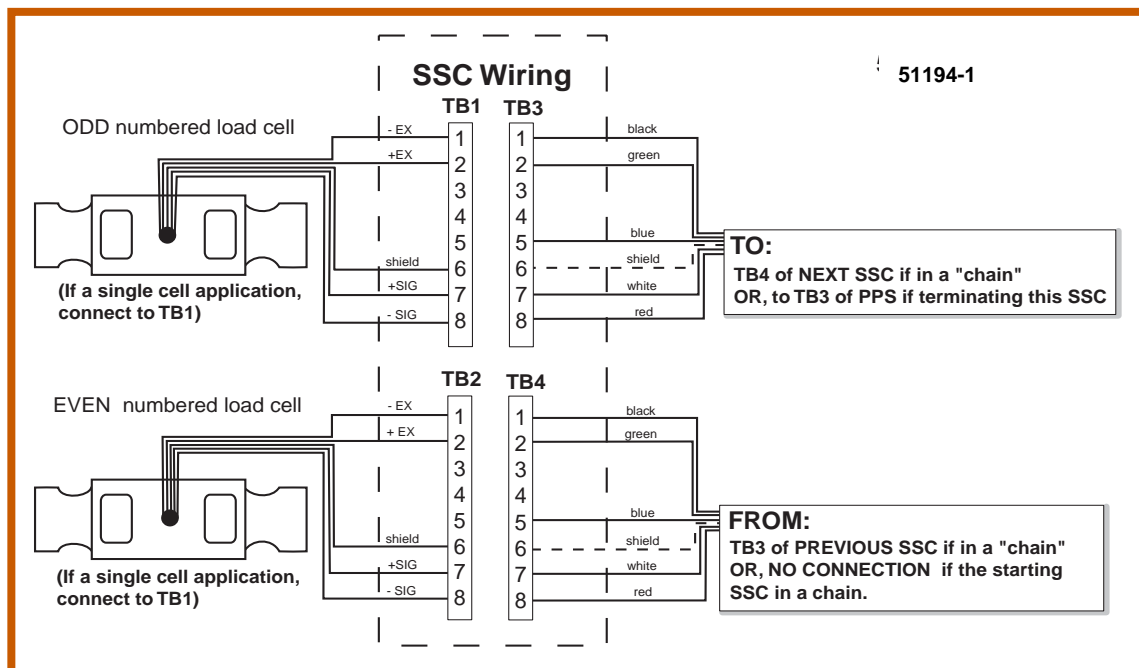

LOAD CELL WIRING, CONTINUED

2. Wire the SSCs to each other.

SSC-to-SSC 'Daisy Chain' Connections

Terminal Number	Function	15602 Cable Color
1	(-) 8.0 volts	Black
2	(+) 8.0 volts	Green
5	DC Return	Blue
6	Shield	Shield
7	RS-485 (+)	White
8	RS-485 (-)	Red

NOTE: On the **15602 Cable**, don't use the **Orange wire**.

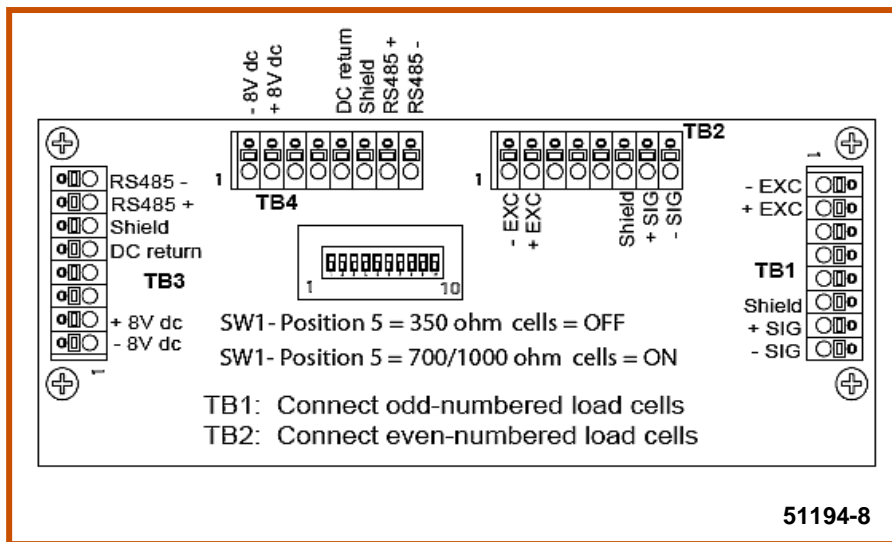

3. Set the Switches

Dip (Address) Switch Setup, SSCs

- In each of the smart SSC boxes there is a 10-position dip switch labeled **S1**.
- This switch is used to identify the section in a binary code.
- The switches must be set properly for the scale to operate.

NOTE: Switches 1, 2, 3 and 4 are always **OFF**.

LOAD CELL WIRING, CONTINUED

- Switches 6 thru 10 are used to set the section (address) numbers.

Set the section number according to the following chart.

Section Number	Switch Settings				
	6	7	8	9	10
Section 1	On	Off	Off	Off	Off
Section 2	Off	On	Off	Off	Off
Section 3	On	On	Off	Off	Off
Section 4	Off	Off	On	Off	Off
Section 5	On	Off	On	Off	Off
Section 6	Off	On	On	Off	Off
Section 7	On	On	On	Off	Off
Section 8	Off	Off	Off	On	Off
Section 9	On	Off	Off	On	Off
Section 10	Off	On	Off	On	Off
Section 11	On	On	Off	On	Off
Section 12	Off	Off	On	On	Off
Section 13	On	Off	On	On	Off
Section 14	Off	On	On	On	Off
Section 15	On	On	On	On	Off
Section 16	Off	Off	Off	Off	On

- Continue in this manner until each smart SSC box has a unique section number entered on the dip switches.

POWER SUPPLY WIRING

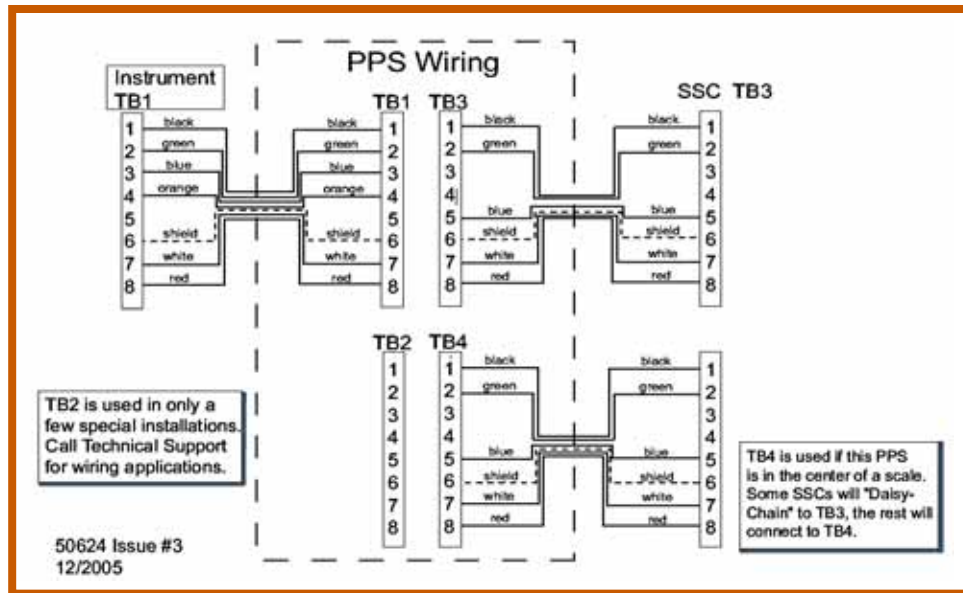

1. Connect the PPS to an SSC (#1 or any SSC).

- Feed a cable from SSC#1 TB3 through the bushing for in the PPS for TB3 and make connections as follows:

TB3 SSC#1	TB3 PPS	15602 Cable	Description
1	1	Black	(-) 8.0 volts
2	2	Green	(+) 8.0 volts
5	5	Blue	DC Return
6	6	Shield	Shield
7	7	White	RS-485 (+)
8	8	Red	RS-485 (-)

2. Wire the PPS to the Instrument.

- Run the 'Home-Run' cable from the PPS, TB1 to the Instrument's TB1, wire as follows:

TB1 PPS	TB1 Inst	17246 Cable	Description
1	1	Black	28 VAC
2	2	Green	AC Return
3	3	Blue	20 VDC
4	4	Orange	Enable
6	6	Shield	Shield/DC Return
7	7	White	Transmit
8	8	Red	Receive

NOTE: Shields are used for DC Return and **MUST** be connected.

GROUNDING

For accurate operation and protection against damage from lightning strikes, all of the components of the system must be properly grounded. The grounding system contains ground rods for the scale location. Below are points to correctly ground the system:

- It is recommended that the grounding be done with **#8 or larger wire, or braided ground straps**.
- All of the ground connections should be **two (2) feet** or as short as possible.
- The case of the SSCs and PPSs must be attached in a clean electrical connection to the platform frame.
 - The platform frame is then connected to a scale ground rod.
- The **insulated WHITE wire from the PPS** connects directly to the separate ground rod (not to the same rod as the steel).
- The **117 VAC SVP Unit (23143)** must be connected to a known good ground at the instrument location.
 - Use a voltmeter to test the electrical power source available for the Neutral-to-Ground voltage level.
 - *It must be* **0.2VAC or LESS**.

DATA RECORDING

- Record the scale serial numbers from the tag.
- Record the instrument, SSC, PPS, and load cell serial numbers.
- Keep a copy of the sheet in the customer file.
- Use Appendix II for additional information.

Full Electronic Scales are designed to provide protection from moisture.

- The load cells are calibrated with the cable attached, and therefore **the cable should NOT be cut**.
- The cable is connected directly to the SSC through a sealed bushing which **MUST be tightened** with pliers to keep water/moisture out of the box.
- All cabling should have a "drip loop" at the cell or box entry location to help prevent water entry.
- On all boxes, the gland fittings have O-rings that can be forced out of position if the bushing itself is not tight.
 - *To prevent this, first tighten the inner nut securing the bushing in the hole, then insert cable and carefully tighten gland with pliers until it is very snug.*
 - *Do not over-tighten where bushing 'turns.*
- All box covers **MUST** be secured.

Section 5: Calibration

INITIAL ZERO AND SPAN ADJUSTMENTS

1. Seat the suspension components.
 - a. Drive the test truck across the scale stopping and starting several times.
 - b. *Repeat this procedure **at least three times** to assure that all parts are properly seated.*
2. The zero and span of the scale need not be set perfectly, but it should be roughly adjusted to check for repeatability.
 - a. Return to zero and to properly adjust the section readings.
3. Refer to the appropriate technical manual for the scale indicator for the initial and span calibration procedures.
4. Perform the coarse initial and span adjustments.
 - a. Final zero and span adjustments are performed after adjusting the sections.

REPEATABILITY AND RETURN-TO-ZERO PERFORMANCE TESTS

1. Position the test truck in the center of the Weighbridge.
2. Note the weight reading.
3. Pull the truck off the scale and note the return to zero.
 - a. Repeat this procedure at least three times to check consistency.
 - b. If the scale does not repeat the readings, within tolerance, check for mechanical obstructions.
 - c. Check the scale thoroughly for proper assembly
 - d. Check the load cells for proper alignment.

NOTE: *This is best accomplished with the **AZT disabled**.*

SECTION TEST AND ADJUSTMENT, ANALOG SYSTEMS

- The section test should be conducted centering the test load over each section.
 - A weight cart, block weights, rear axles of the test truck.
 - Note the weight indication of each section.
 - The sections should be adjusted so the weight indications of all sections match within the tolerances set forth by the **National Institute of Standards and Technology's Handbook H-44.**
 - Trim the sections by adjusting a potentiometer in each of the sections.
 - This changes the output of that section.
 - The normal trimming procedure lowers the readings of the higher sections to match the reading of the lowest section.
 - The **Section and Corner Trim Potentiometers** are located on the Junction Box summing board, which is mounted in a protective cavity on the Weighbridge.
 - To access the Summing Board located on the side of the main beam exposing the Junction Box, remove the Junction Box Cover and Gasket.
 - Keep dirt, dust, moisture or other debris from the Junction Box, as damage to the Summing Board may occur.
 - Place the test load over each section and adjust the corresponding trim potentiometer, if necessary, so that the weight indication equals that of the lowest section.
 - Due to a small interaction which may occur between sections, it may be necessary to repeat this procedure in order to bring the sections within tolerance.
1. Replace the Junction Box Gaskets and Covers.
 2. Secure the covers properly

SECTION TEST AND ADJUSTMENT, INTALOGIX™ TECHNOLOGY SYSTEMS

- Follow setup and programming instructions in the appropriate Intalogix™ Technology manual.
- Use a weigh cart or weights placed directly over the section for proper trimming.

DIGITAL INDICATOR SPAN CALIBRATION ANALOG OR INTALOGIX™ TECHNOLOGY

- Perform the initial and span adjustments, following the appropriate scale indicator technical manual.

Section 6: Parts

SCALE COMPONENTS

Item #	Part #	Description
1	66971	1/16" Pin Seat Shims
2	66974	1/8" Pin Seat Shims
3	72807	Module Shim, 1/8"
4	76601	Corner Stand, DB Load Cell
5	64812	Load Pin
6	66347	Link 1-1/4"
7	64824	Dowel Pin, 5/8" Dia. X 1" Long
8	64822	Pin Seat
9	54769	Lock Washer, 1/2"
10	54401	Bolt, 1/2"-13 x 3"
11	61743	Clamp Bar
12	60237	1"-8 x 5 Hex Head Full Thread Bolt
13	54782	1" Spring Lock Washer
14	54249	1" Flat Washer, Zinc
15	54277	1-8 Hex Nut, Zinc
16	107329	Load Cell, 100K DE Shear Beam, 3mV/V (20' Cable)
17	54304	1 1/8-7 Hex Nut
18	75698	1 1/8-7 x 8" Full Thread Bolt
19	62857	Wedge Anchor, 5/8" x 6
No Ref	106519	Grommet, Rubber
No Ref	23143	Surge Protector, AC
No Ref	65058	Surge Protector, DC (Used for Analog Systems only)
No Ref	55010	Ground Kit

ANALOG SCALE COMPONENTS

Part #	Description
21912	Junction Box with Summing PCB
21842	Summing PCB

INTALOGIX™ TECHNOLOGY SCALE COMPONENTS

Part #	Description
27926	Sectional Controller Assembly (SSC)
26164	SSC Box
26080	SSC PCB Only
24723	Pit Power Supply Assembly (PPS)
15646	Pit Power Supply Box
23393	Pit Power Supply PCB only
17545	Connector, Liquid Tite (small)
17535	Connector, Liquid Tite (large)

SCALE COMPONENTS, CONTINUED

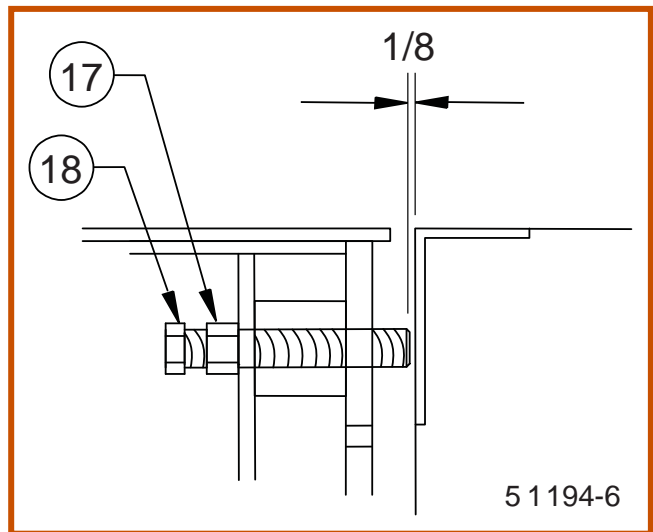
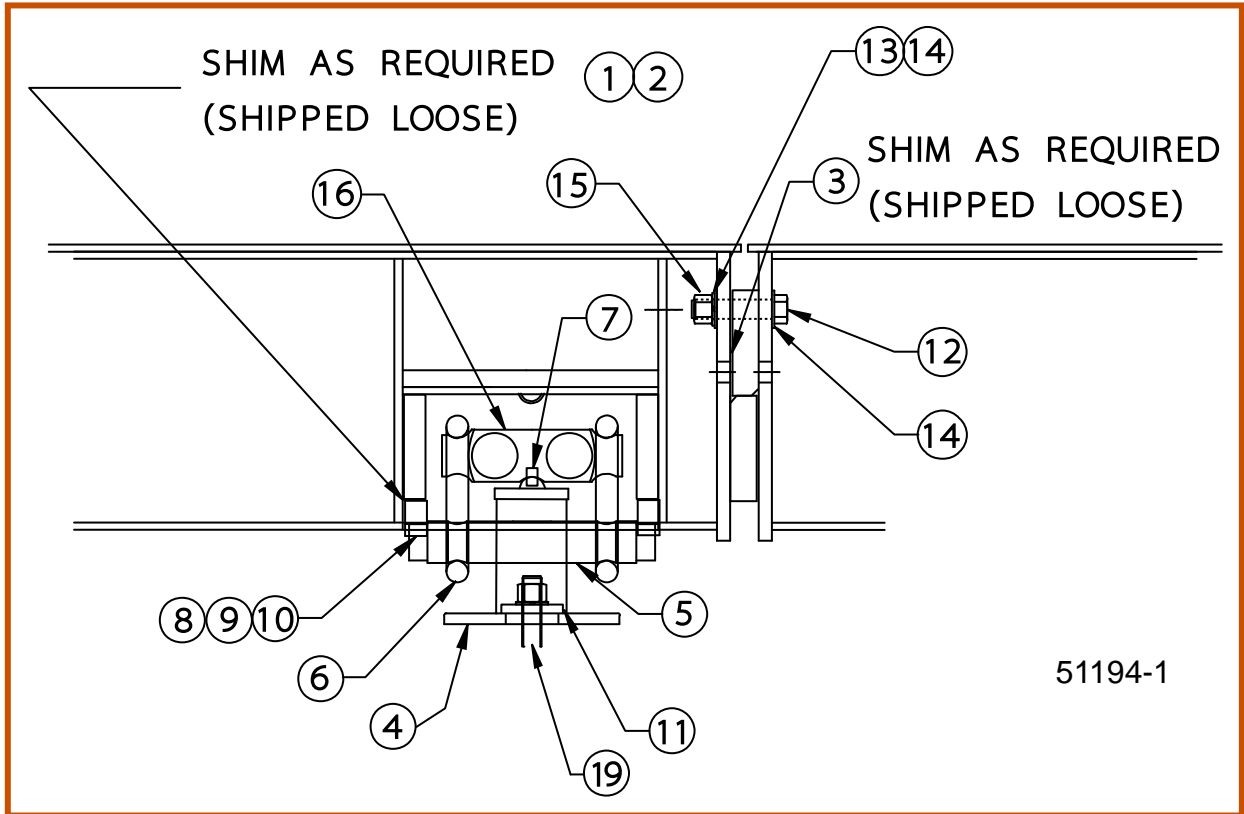

Appendix I: Wiring

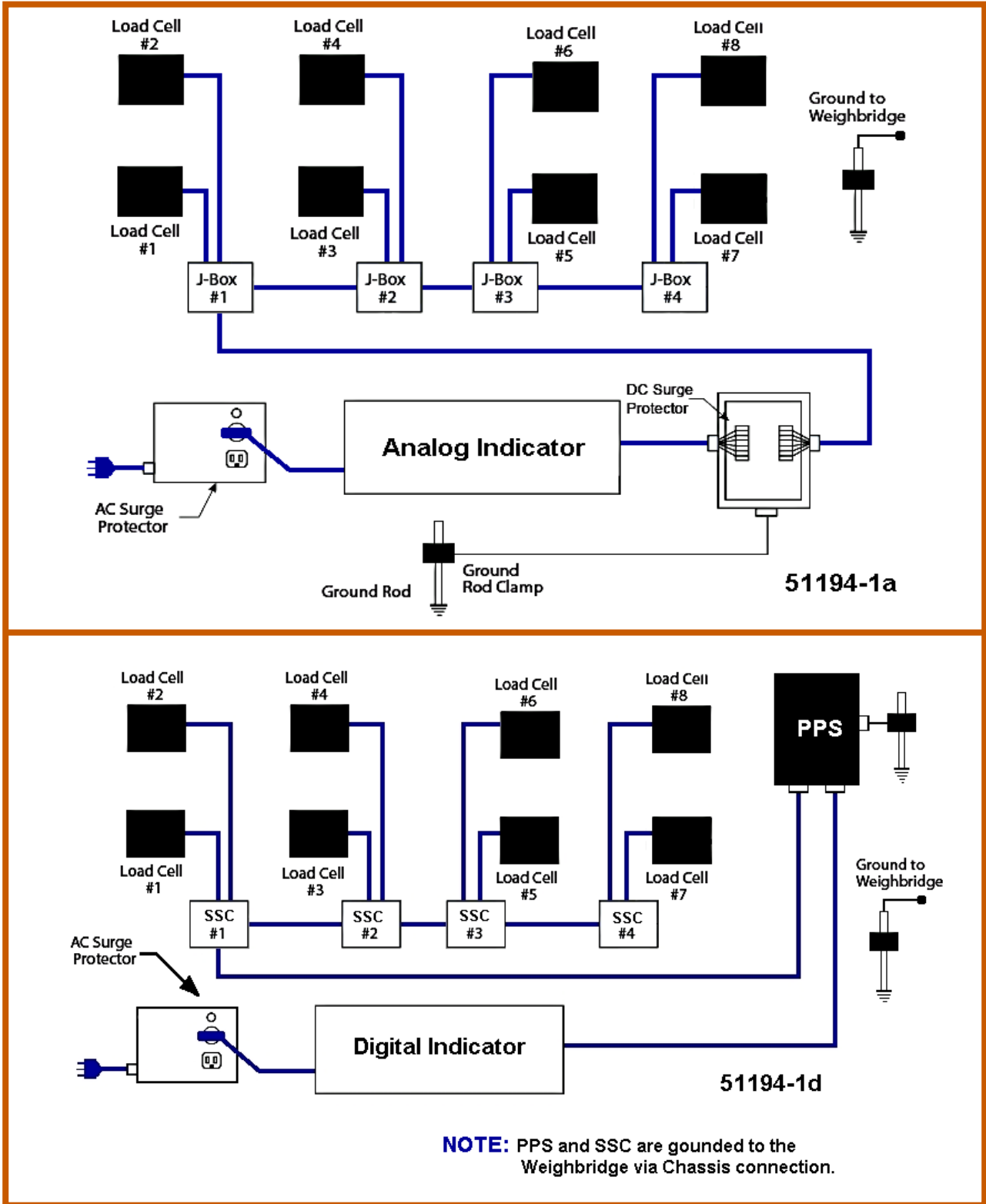

Appendix II: Data Recording

Location/Name _____ Phone # _____

Scale Model _____ Serial _____

Date Installed _____

Date placed in service _____

Installer's Name _____

Instrument Model _____ Serial _____

Load Cell #1 Serial _____

Load Cell #2 Serial _____

#1 SSC or J Box Serial _____

Load Cell #3 Serial _____

Load Cell #4 Serial _____

#2 SSC or J Box Serial _____

Load Cell #5 Serial _____

Load Cell #6 Serial _____

#3 SSC or J Box Serial _____

Load Cell #7 Serial _____

Load Cell #8 Serial _____

#4 SSC or J Box Serial _____

PPS Serial _____

Location/Name _____ Phone # _____

Scale Model _____ Serial _____

Date Installed _____

Date placed in service _____

Installer's Name _____

Instrument Model _____ Serial _____

Load Cell #1 Serial _____

Load Cell #2 Serial _____

#1 SSC or J Box Serial _____

Load Cell #3 Serial _____

Load Cell #4 Serial _____

#2 SSC or J Box Serial _____

Load Cell #5 Serial _____

Load Cell #6 Serial _____

#3 SSC or J Box Serial _____

Load Cell #7 Serial _____

Load Cell #8 Serial _____

#4 SSC or J Box Serial _____

PPS Serial _____



Manufactured by **Thurman Scale**
255 East Livingston Avenue
Columbus Ohio, 43215

Diamondback XD Truck Scale

Document 51194

Installation Manual